

CONTROL VALVES

Pressure Reducing
Low Pressure +
High Pressure
Diaphragm

Balanced
Back Pressure
Safety & Relief
Drip Pan Elbows

800-KECKLEY (800-532-5539)

847/674-8422

FAX: 847/674-2106

E-MAIL: SALES@KECKLEY.COM

WEB SITE: WWW.KECKLEY.COM

NO QUESTION. WE HAVE THE ANSWERS.

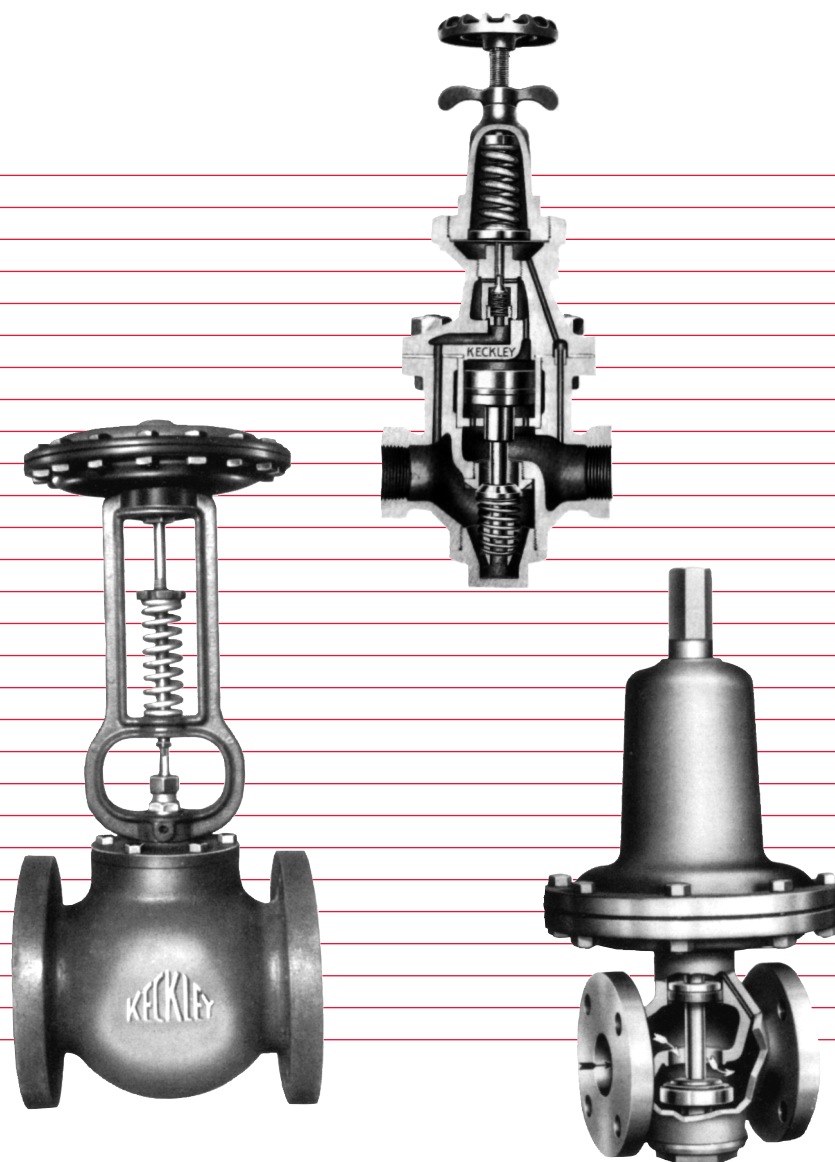

How to Order:

1. Name of Regulator, Figure Number, Type, or Catalog Reference.
2. Pipe size of valve.
3. Service (steam, water, air, etc.)
4. Operating Pressures. (Give inlet pressure and required control pressure.)
5. Capacity Requirements.
6. Operating Temperature.
7. Shipping Instructions.

Conditions of Sale:

Prices are F.O.B. Plant, and are subject to change without notice.

All Specification data herein given are subject to change without notice.

Claims for shortage must be made immediately upon receipt of goods.

No material to be returned without written authorization.

We shall not be liable for any special direct, indirect or consequential damages.

No claims for damages, labor or other expense on material furnished will be allowed unless authorized in writing.

All agreements contingent upon strikes, accidents or other causes beyond our control.

All orders are subject to final acceptance and approval by the factory.

Applicable price list does not include excise, sales, use, occupation, or other taxes levied on sales transactions. All such taxes will be billed to our customers.

The Company:

Since 1914, KECKLEY engineering and manufacturing has been working for industry and commercial building installations worldwide. KECKLEY products excel in their construction and performance.

With the purchase of Klipfel Valves Inc. in 1962, there was a combining of engineering talents and features of both valve companies resulting today in this complete line.

This Bulletin describes and illustrates these valves:

Pressure Reducing
Diaphragm
Back Pressure
Safety & Relief
Drip Pan Elbows

For more information on KECKLEY Float and Lever Valves, refer to Bulletin No. 8711-7; and for Strainers, Strainer Section.

Sales Engineers and Industrial Distributors:

ALASKA

Anchorage

ALABAMA

Birmingham
Mobile
Montgomery

ARIZONA

Phoenix

ARKANSAS

Little Rock

CALIFORNIA

Los Angeles
San Francisco

COLORADO

Colorado Springs
Denver

DELAWARE

Wilmington

DIST. OF COLUMBIA

Washington

FLORIDA

Jacksonville
Miami
Orlando
Tampa

GEORGIA

Athens
Atlanta
Augusta
Macon

HAWAII

Honolulu

IDAHO

Boise

ILLINOIS

Chicago
Rockford
Springfield

INDIANA

Ft. Wayne
Indianapolis
Kokomo

IOWA

Davenport
Des Moines

KANSAS

Kansas City
Wichita

KENTUCKY

Louisville
Owensboro
Paducah

LOUISIANA

New Orleans
Shreveport

MARYLAND

Baltimore

MASSACHUSETTS

Boston

MICHIGAN

Detroit
Grand Rapids
Kalamazoo

MINNESOTA

Minneapolis
St. Paul

MISSISSIPPI

Jackson

MISSOURI

Kansas City
St. Louis

MONTANA

Billings

NEBRASKA

Omaha

NEW JERSEY

Hackensack

NEW MEXICO

Albuquerque

NEW YORK

Buffalo
New York
Rochester
Syracuse

NO. CAROLINA

Charlotte
Raleigh
Winston Salem

OHIO

Cincinnati
Cleveland
Toledo

OKLAHOMA

Oklahoma City
Tulsa

OREGON

Portland

PENNSYLVANIA

Philadelphia
Pittsburgh

SO. CAROLINA

Greenville

TENNESSEE

Kingsport
Knoxville
Memphis
Nashville

TEXAS

Dallas
El Paso
Fort Worth
Houston
San Antonio

UTAH

Ogden
Salt Lake City

VIRGINIA

Norfolk
Richmond
Roanoke

WASHINGTON

Seattle
Spokane

WEST VIRGINIA

Charleston
Huntington

WISCONSIN

La Crosse
Milwaukee

CANADA Toronto, Ontario-Montreal, Quebec-Vancouver, British Columbia-Winnipeg, Manitoba-Saskatoon, Saskatchewan-Regina, Saskatchewan

TABLE OF CONTENTS

	Page		Page
How to Order/Conditions of Sale	2	Diaphragm Regulating Valves — Double Seated	
Introduction/Distributors	3	Types 114 and 114R	10
Table of Contents	4	Types 116 and 116R	10
Pressure Regulators — Internal Pilot	5	Diaphragm Regulating Valves — Single Seated	
Types AA and AR (Steam-Air)	6-7	Types 119 and 119R	11
Pressure Regulators		Types 118 and 118R	11
Type 700 (Liquid-Air)	8	Back Pressure Valves	
Type 701 (Water)	9	Types 135 and 145	18
Pressure Reducing Valves		Types 135/145 Capacity Tables	19
Type 10	12	Bronze Safety and Relief Valves	
Type 11-A	13	Types 40 and 41 (Steam or Air) ASME	20
Type D	14	Types 42, 43 and 44 (Liquids)	20
		Capacities	21
		Iron and Steel Safety Valves	
		Type 301 ASME	22
		Types 401 and 402 ASME	22
		Capacities and Dimensions	23
		Drip Pan Elbows	15
		Regulator Water Capacity Table	15
		Regulator Steam Capacity Table	16
		Regulator Air Capacity Table	17

Request Float and Lever Valve Bulletin No. 8711-7

Request Strainer Section

TYPE AA, AR REGULATING VALVES

Renewable Parts

Identification of Internal working parts:

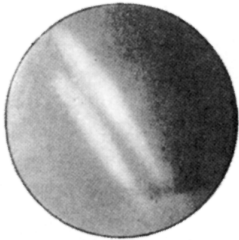

DIAPHRAGM No. 11



MAIN VALVE No. 26



MAIN VALVE SPRING No. 27

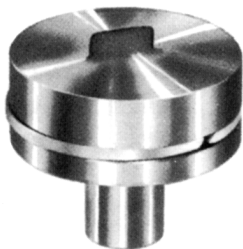

PISTON WITH RING No. 21

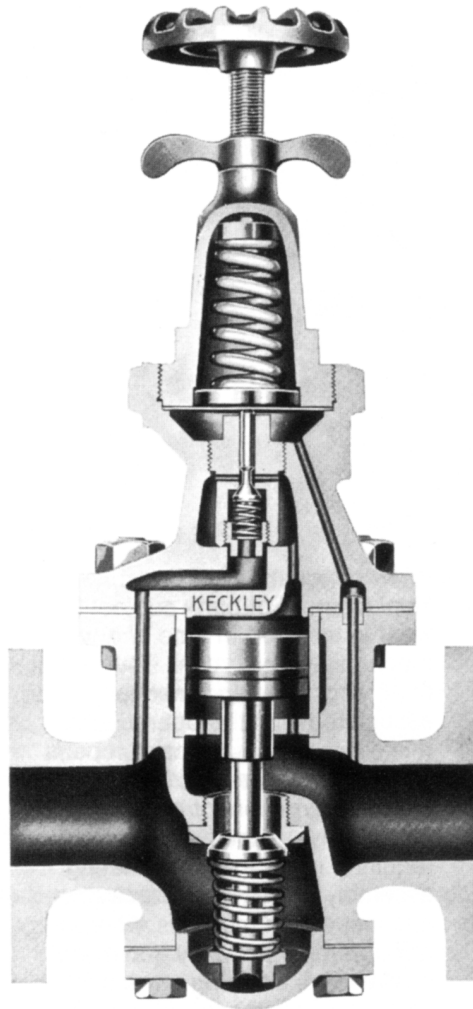

TYPE AA



CYLINDER LINER No. 23

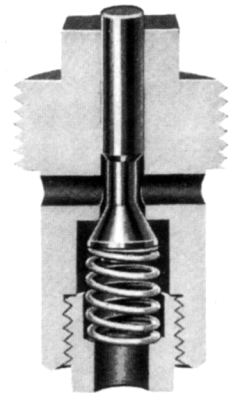

UNIT PILOT VALVE No. 12



ADJUSTING SPRING No. 8



MAIN VALVE SEAT No. 25

CROSS SECTION OF TYPE AA AND IA REGULATING VALVE SHOWING RELATION OF COMPONENT PARTS. NOTE ACCESSIBILITY TO EVERY PIECE OF VALVE CONSTRUCTION. SIZES 1/2" TO 6" SCREWED OR FLANGED.

Tested and Approved - U.S. Navy for design - materials - workmanship and operation.

TYPE AA, AR PRESSURE REGULATORS

Bronze Body
Steam — Stainless Steel Trim (Max. 300 psi Inlet)
Air — Nylon Trim (Max. 600 psi Inlet)
Internal Unit Pilot Valve

The Keckley Precision Pressure Regulator has for its greatest advantages simplicity in design, unit pilot valve construction, and the use of stainless steel for parts subject to the most wear, which can be renewed at a nominal cost.

The main valve seat of stainless steel is inserted from the bottom of the body. The piston above the valve, where dirt and sediment will not affect its operation, rides in a cylinder liner which can be easily replaced. The pilot valve cage is screwed into the top cap as a complete unit, with valve and spring. Directly above the pilot valve is the diaphragm held down by the adjusting spring case.

The main valve is opened by high pressure acting on the large piston directly above it. The pilot valve, working in conjunction with the diaphragm, actuated by any unbalanced effect of the adjusting spring and low pressure beneath it, controls accurately the necessary pressure to the piston. Thus the pilot valve, extremely sensitive to the secondary pressure, opens and closes the main valve in a proportionate degree to maintain the desired constant low pressure at all times.

Sudden fluctuations in initial pressure are prevented from reaching the secondary side by the expansion chamber effect of the piston cylinder.

The Keckley Regulator is made of the finest materials with precision workmanship and is thoroughly tested under all operating conditions. This regulator, therefore, offers maximum

efficiency not only as to close regulation but also as to dependability through years of service.

Type AA for reduced steam or air pressure above 40 psi: Type AA Regulators are recommended for reduction of pressures from the maximum pressure in one step to pressure above 40 psi. For pressures below 40 psi, we recommend the Type AR Precision Pressure Regulator as described below. It is necessary to have a minimum difference of 15 psi between initial pressure and reduced pressure for proper valve operation.

Type AR for reduced pressures from 2 to 40 psi: For reduction of pressure to 40 psi or less, the top cap of the regulator is furnished with larger diaphragm and provided with remote control connection, and is designated as Type AR. Remote control connection should be installed in the line to be controlled on the reduced pressure side of the regulator.

Operation: Remove all tension from the adjusting spring by turning handwheel to the left, which closes pilot valve and main valve of the regulator. Then open wide the stop valve on the high pressure side of the line. Increase tension slowly on the adjusting spring by turning handwheel to the right until the desired low pressure is reached, after which the stop valve in the low pressure side can be opened. When the regulator is in operation, keep both stop valves fully open and locknut on adjusting screw tight.

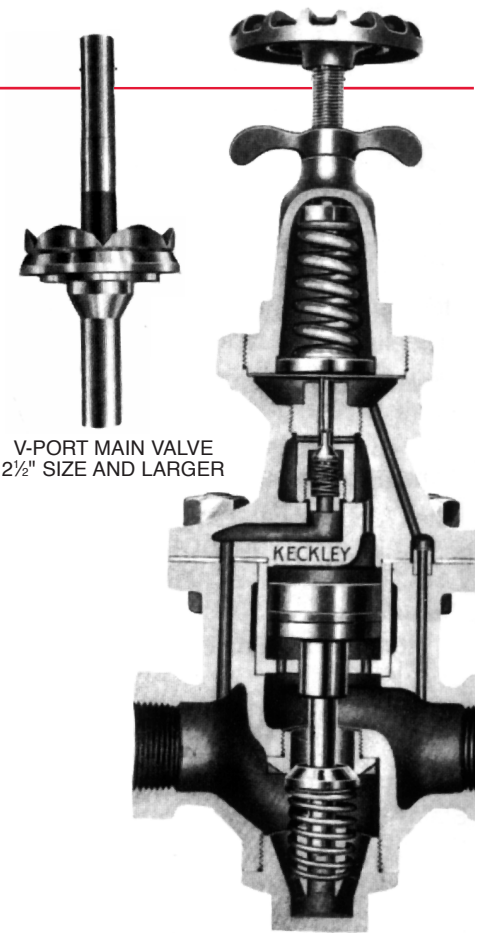

V-PORT MAIN VALVE
2 1/2" SIZE AND LARGER

TYPE AA REGULATING VALVE
SIZES 2 1/2" TO 6"
SCREWED OR FLANGED

The Keckley Precision Pressure Regulator can be adjusted to any desired pressure within the range of the regulating spring and diaphragm by merely turning the handwheel at the top of the regulator to the right for higher secondary pressure, and to the left for lower secondary pressure.

See pages 16-17 for recommended sizes at various capacities.

TYPE	Size	INLET PRESSURE RANGE		REDUCED PRESSURE RANGE		Approx. Variation in Reduced Pressure Setting
		Steam	Air	Minimum	Maximum	
Type AA	1/2"-2 1/2"	55-300 psi		40 psi	285 psi	3% of inlet Press. over 100 psi
	3"-6"	55-300 psi		40 psi	285 psi	5% of inlet Press. over 100 psi
Type AR	1/2"-2 1/2"	25-300 psi		2 psi	40 psi	2% of inlet Press. over 100 psi
	3"-6"	25-300 psi		5 psi	40 psi	5% of inlet Press. over 100 psi

For Air service with nylon trim to 600# inlet, same Minimum Reduced Pressure % factors apply. Must have at least 25 psi initial pressure.

	INLET PRESSURE RANGE		REDUCED PRESSURE RANGE	
	Air	Steam	Air	Steam
Type AA	60-600 psi		40-585 psi	
Type AR	25-600 psi		2-40 psi	

Must have at least 25 psi initial pressure.

TYPE AA, AR PRESSURE REGULATORS

Specifications:

BODY CASTINGS: Bronze.

MAIN VALVE: Stainless steel, accurately machined, ground and polished.

MAIN VALVE SEAT: Stainless steel with seat ground and polished. Screwed into body. Readily removable and renewable.

DIAPHRAGM: Phosphor bronze rolled to accurate thickness.

SPRINGS: Stainless steel, impervious to tension changes due to temperature variations. Accurately wound. Ends ground square.

PISTON: Government bronze, accurately machined and readily removable. Carries piston ring of high resiliency and sealing characteristics.

PISTON CYLINDER: Renewable cylinder liner with integral head of government bronze or stainless steel.

GASKETS: Non asbestos (copper jacketed), both under main valve cap and between body and body cap offer maximum resistance to leakage.

PILOT VALVE: The pilot valve, spring and cage is of course the "HEART OF THE REGULATING VALVE." For this reason we have designed this portion of the Keckley Regulating Valve so that it is removable as a unit. Compare this unit construction with other types where the various component parts of the pilot valve must be removed individually. Valve and cage are stainless steel, accurately ground and polished.

NYLON is used for both the pilot valve and main valve, guaranteeing positive shut-off on air service.

STELLITED SEAT RINGS for the main valve and main valve seat can be furnished for extreme operating conditions where high pressure and temperature is a major factor.

Capacity table, see pages 16-17.

DATA REQUIRED WHEN ORDERING:

- Inlet Pressure
- Outlet Pressure
- Media
- Capacity

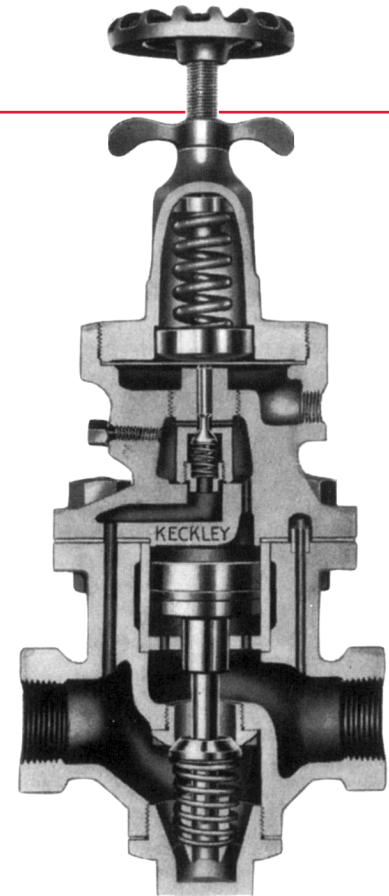

TYPE AR REGULATING VALVE
SIZES 1/2" TO 6"
SCREWED OR FLANGED

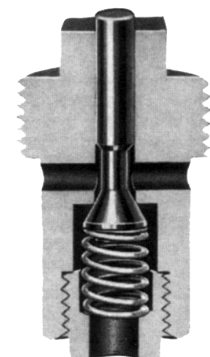

UNIT PILOT
VALVE OF
TYPE AA AND AR
REGULATORS

DIMENSIONS • BRONZE—300# • 150# AND 300# ASA FLANGES (approximate)

Size	Face to Face			Center to Bottom	Center to Top	Total Height	Diam. of Flanges	Thick. of Flanges	Bolt Circle	No of Bolts	Size of Bolts	Diam. of Bolt Hole	Ship Weight		
	Screwed	Flanged											Screwed	150#	300#
		150#	300#												
1/2	5%	6%	6%	2 1/16	11 1/16	13 3/8	3%	1/2	2%	4	3/8	7/8	22	28	29
3/4	5%	6 1/16	6 1/16	2 1/16	11 1/16	13 3/8	4%	1 1/32	3 1/4	4	3/8	7/8	22	28	29
1	5%	6%	6 13/16	2 1/16	11 1/16	13 3/8	4%	1 1/32	3 1/2	4	3/8	7/8	22	28	29
1 1/4	6	6 1/16	7%	2%	11 1/2	14%	5%	5/8	3%	4	3/8	7/8	23	30	32
1 1/2	6 1/4	7 1/16	7%	3 1/16	11%	14 15/16	6%	1 1/16	4 1/2	4	3/8	7/8	27	37	39
2	7 1/2	8 1/2	9	3 1/2	12 1/16	15 5/16	6 1/2	3/4	5	8	3/8	7/8	42	51	54
2 1/2	—	9 1/2	10	4%	13%	17%	7 1/2	1 1/16	5%	8	3/8	7/8	—	72	75
3	—	10%	11 1/16	5 1/16	13%	19 5/16	8%	2 1/32	6%	8	3/8	7/8	—	112	115
4	—	12 1/16	13 3/16	7 1/8	15 5/16	22 11/16	10	1 1/16	7%	8	3/8	7/8	—	218	221
5	—	13%	14%	9 1/16	16%	26 1/16	11	1%	9%	8	3/8	7/8	—	295	300
6	—	15%	15%	9 3/16	18%	28%	12 1/2	1 1/16	10%	12	3/8	7/8	—	395	400

TYPE 700 WATER PRESSURE REGULATOR

Spring Diaphragm Type
Adjustable Spring Range 8-30; 28-50; 45-75; 70-100

Service: The Type 700 is an improved design of the best type of water pressure reducing valve in small sizes for silent, dead end operation, especially for supplying low or medium water pressure to buildings from high pressure city water mains. Because they are dependable, tight closing, compact, and rarely require attention they are in use for fresh and salt water systems on many naval and merchant ships. No. 700 valves are made for initial pressures up to 300 psi. The delivery pressures are sufficiently high for ordinary service water uses but limited only to insure long diaphragm life, good regulation and to avoid damage to plumbing fixtures.

Construction: In the design of these valves special attention has been given to provide large flow passages; rugged construction for durability and to assure perfect alignment and free operation under pipe strains; accessibility for replacement of the rubber disc, diaphragm, or leather cup without removing from the line; and a better spring design for constant pressure over a wide range of capacity.

Standard valves have bronze bodies and cast iron spring chambers in size 1½ inches and smaller, cast iron bodies and spring chambers in the larger sizes, with bronze trim in all sizes. **For marine service, the bodies and spring chambers are usually furnished in all bronze material at extra cost.**

Operation: The inlet water pressure acts upward on the piston (sealed by a leather cup) and downward on the disc holder carrying a rubber ring disc. The inner valve is consequently balanced and unaffected by changes in inlet pressure.

The valve is held open by the spring until the delivery pressure, transmitted through the diagonal drilled hole to the space under the diaphragm, is sufficient to lift the diaphragm and pull the valve closed.

Water capacity table page 15.

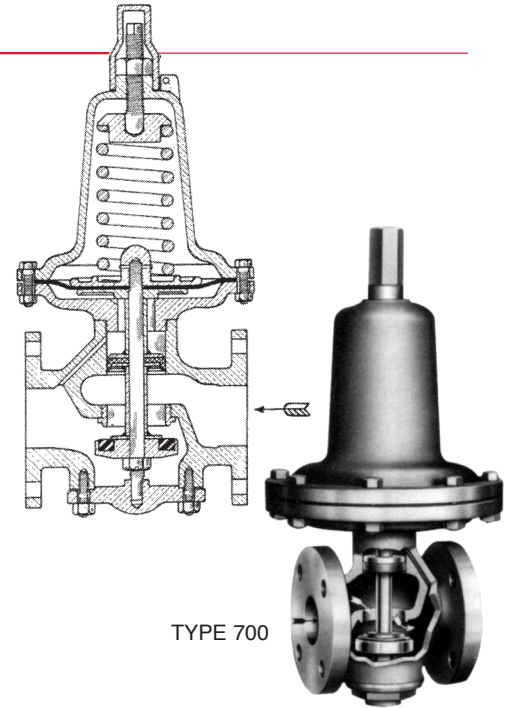

TYPE 700

INITIAL PRESSURE AND TEMPERATURE LIMITS

Body: Bronze or Cast Iron, Scrd.
Air-Water: 300 psi 150°F.
Not used for steam

Body: Cast Iron, 125 lb. Flanges
Air-Water: 200 psi 150°F.
Not used for steam

Body: Cast Iron, 250 lb. Flanges
Air-Water: 300 psi 150°F.
Not used for steam

Higher Temperatures—Consult Factory

Reduced Pressures

Different springs required to cover this range each adjustable over part of range. Spring ranges —8 to 30; 28 to 50; 45 to 75; 70 to 100.

DIMENSIONS—WEIGHTS (approximate)

	DIMENSION—INCHES						SHIPPING WEIGHTS			
	Face to Face			Center Line to Top	Center Line to Bottom	Diameter Diaphragm Chamber	Screwed	Flanged		
	Screwed	125#	250#					125#	250#	
½-¾	3¾	—	—	9¾	1¾	5	16	—	—	
1	4¾	—	—	10¾	2¾	6	20	—	—	
1¼	4¾	—	—	13¾	2¾	8	30	—	—	
1½	5¾	—	—	14¾	2¾	8	40	—	—	
2	8¾	7¾	8	14¾	3¾	8	55	60	65	
2½	9¾	9¾	10¾	18¾	4¾	9¾	140	150	155	
3	11¾	10¾	11¾	24	6	12	210	225	240	
4	—	11¾	11¾	24¾	6¾	12	—	270	290	

TYPE 701 WATER PRESSURE REGULATOR

External Pilot Type
Adjustable Spring Range 8-30; 28-50; 45-75; 70-100

Service: The Type 701 water reducing valve is intended for use wherever water at a higher pressure is to be reduced to a pressure between 8 and 100 p.s.i. and where a tight closing valve of heavy and durable construction is needed. Typical applications are on the discharge of pumps supplying water for general plant use and for regulating pressure on plumbing systems.

Materials: The valve body and cover are cast iron. The internal parts are bronze except the rubber disc and leather cup. Sizes 2, 2½ and 3 inch have screwed or flanged ends. Larger sizes made with flanged ends only.

Construction: The inner valve carries a rubber composition disc which closes against a renewable seat bushing. The upper part of the inner valve is a piston, fitted with a leather cup and sliding in a cylinder. The piston has a larger area than the seat bore. The pilot valve is a ½" **No. 100 diaphragm control valve** with needle point main valve.

Operation: When the reduced pressure is below normal, a small amount of water flows continuously through the restricting needle valve and pilot valve into the low pressure pipe. As the water pressure transmitted

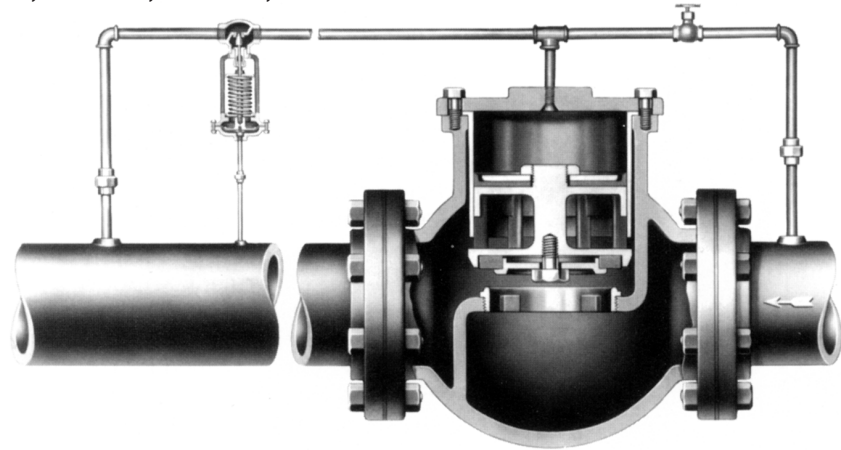

through the tee to the top of the piston is considerably lower than the inlet pressure under the disc, the inner valve is held open. When the reduced pressure under the diaphragm of the pilot valve exceeds normal, the pilot valve begins to close, causing the pressure above the main valve piston to increase and force the inner valve toward the seat until normal reduced pressure is restored.

Adjustment: The reduced pressure can be adjusted to the desired valve by means of the pilot valve spring. The restricting valve is used to control the speed of operation of the main valve. When this needle valve is nearly closed the reduced pressure is kept within closer limits and the main valve opens quickly but closes slowly.

INITIAL PRESSURE AND TEMPERATURE LIMITS

Body: Cast Iron, Screwed
Water: 250 psi 125°F.
Not used for air or steam

Body: Cast Iron, 125 lb. Flanges
Water: 200 psi 125°F.
Not used for air or steam

Body: Cast Iron, 250 lb. Flanges
Water: 250 psi 125°F.
Not used for air or steam

Higher Temperatures—Consult Factory

Reduced Pressures
Different springs required to cover this range each adjustable over part of range. Spring ranges —8 to 30; 28 to 50; 45 to 75; 70 to 100.

Water capacity table page 15.

DIMENSIONS—WEIGHTS (approximate)

Size Inches	Dimensions Globe—F. to F.—Inches			Dimensions Angle—Cen. to Flg.—Inches			Shipping Weight		
	Screwed	Flanged		Screwed	Flanged		Screwed	Flanged	
		125#	250#		125#	250#		125#	250#
2	7 ⁵ / ₁₆	8 ¹ / ₂	8 ³ / ₄	3 ³ / ₁₆	4 ¹ / ₂	4 ⁵ / ₁₆	43	52	60
2½	8 ¹ / ₂	9 ¹ / ₂	10 ¹ / ₂	3 ¹ / ₂	4 ³ / ₄	5 ¹ / ₁₆	53	65	72
3	9 ¹ / ₂	10 ¹ / ₂	11 ¹ / ₂	4 ¹ / ₂	5 ¹ / ₂	5 ⁵ / ₁₆	73	85	100
4	—	12 ¹ / ₂	12 ¹ / ₂	—	6 ¹ / ₂	6 ⁵ / ₁₆	—	120	140
5	—	14 ¹ / ₂	15 ¹ / ₂	—	7 ¹ / ₂	7 ¹ / ₁₆	—	170	195
6	—	16 ¹ / ₂	17 ¹ / ₂	—	8 ¹ / ₂	8 ⁵ / ₁₆	—	200	235
8	—	19 ¹ / ₂	20 ¹ / ₂	—	9 ¹ / ₂	9 ⁵ / ₁₆	—	395	445
*10	—	20 ¹ / ₂	21 ¹ / ₂	—	—	—	—	465	520

*Globe pattern only

TYPES 114 • 114R – DOUBLE SEATED • SPRING LOADED
TYPES 116 • 116R – DOUBLE SEATED • WEIGHT LOADED
DIAPHRAGM REGULATING VALVES

Reducing Valve (Normally Open) Pressure to Diaphragm to Close • Relief Valve (Normally Closed) Pressure to Diaphragm to Open • Steam, Air, Gas, Water, Oil Service
 300 lb. Bronze Body • 250 lb. Cast Iron Body



On self contained Regulators for reduced pressures above 60 psi a piston operator is necessary and replaces the diaphragm operator at additional cost.

Type 114 • Type 116: Spring-loading distinguishes the 114 Regulator. Weight-loading distinguishes the 116 Regulator. They are direct connected, diaphragm actuated. A regulator of this design will maintain a given constant pressure reduction under continuous service conditions. The balanced inner valve is unaffected by high pressure fluctuations. When the spring or weight is set for the desired reduced pressure, the regulator will automatically deliver the amount of steam required for any specific operating condition.

This regulator is ideal for heating and gas distributing systems or any service requiring direct operated pressure reduction of Steam, Air, Gas, Water and Oil.

Valves, sizes 1½, and smaller, are usually furnished with bronze bodies and bronze trim. Larger valves have cast iron bodies with bronze trim.

Diaphragm heads are interchangeable and may be had in a number of sizes suitable for various reduced pressure ranges. (6", 7", 8", 10", 13".)

Installation may be made in a horizontal pipe line with the diaphragm either above or below the line or in a vertical line with the stem located in a horizontal plane.

Control pressure is piped to the diaphragm chamber from the reduced pressure line about ten feet ahead of the regulator where an equalized pressure is maintained. The control pressure line should be so located as to form a condensate trap to seal the diaphragm and protect it from the heat of the steam.

A needle valve installed in this line will cushion the action of the main valve. Weight loaded regulators must be installed with diaphragm below a horizontal pipe line.

Type 114-R • Type 116-R double seated relief valve • Reverse acting:

With the exception of a reversed disc, the 114-R and 116-R double seated Relief Valves are of the same general construction as the 114 and 116 Regulator with the same dimensions in all pipe sizes.

The disc is held to its seat by the spring or weight loading and is opened by the pressure to be relieved acting on the diaphragm through pilot piping to the inlet line.

The 114-R and 116-R are best applied in relieving from one pressure line into a lower pressure line as variations in either the inlet or outlet pressure have no effect on its operation because of the balanced disc construction.

Steam and air capacity tables, see pages 16-17. Water capacity table, see page 15.

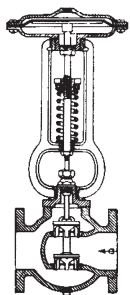

TYPE 114

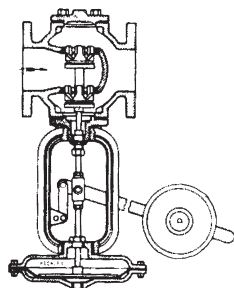

TYPE 116

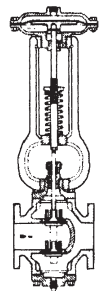

TYPE 114-R

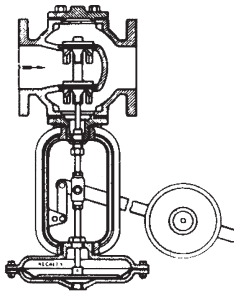

TYPE 116-R

DIMENSIONS (approximate) • TYPE 114 • 114-R
116 • 116-R • 118 • 118-R • 119 • 119-R

Size	½	¾	1	1¼	1½	2	2½	3	4	5	6	8	10	12
Face to Face Screwed	4 ¹ / ₁₆	4 ¹ / ₁₆	4 ¹ / ₁₆	5%	5%	6½	7%	9%	—	—	—	—	—	—
Face to Face Std. Flanged	—	—	—	—	—	6½	8 ⁵ / ₁₆	9%	10%	12	13	16%	20%	22%
Face to Face Ex. Hvy. Flanged	—	—	—	—	—	7	8 ¹ / ₁₆	10	11%	12%	13%	17%	21%	24%

TYPES 119 • 119R – SINGLE SEATED • SPRING LOADED
TYPES 118 • 118R – SINGLE SEATED • WEIGHT LOADED
DIAPHRAGM REGULATING VALVES

Reducing Valve (Normally Open) Pressure to Diaphragm to Close • Relief Valve (Normally Closed) Pressure to Diaphragm to Open • Steam, Air, Gas, Water, Oil Service
 300 lb. Bronze Body • 250 lb. Cast Iron Body

Type 119 • Type 118: This single seated direct connected diaphragm type of regulator is recommended for dead end service where it is required that the valve close tight and maintain a reduction regardless of flow.

The port area is about one-half the pipe area so it is not a suitable type to use where maximum high pressure pipe capacity is required.

The initial pressure is under the disc. Control pressure on the diaphragm must overbalance initial pressure under the disc. The greater the difference between initial and reduced pressures, the larger the diaphragm must be.

Approximate initial and reduced pressures must be known in order to construct a regulator of this type for a given operating condition.

Valves, sizes 1½" and smaller, are usually furnished with bronze bodies and bronze trim. Larger valves have cast iron bodies with bronze trim.

The yoke which joins the valve body and the diaphragm chamber is held in place by set screws. **Recommended installation in order to obtain water accumulation to protect the diaphragm would be to have the valve inverted with the yoke and diaphragm chamber below the line of flow.** Diaphragm heads are interchangeable and are available for most pressure conditions in sizes 6", 7", 8", 10", 13".

Installation: See page 10.

Type 119-R • Type • 118-R single seated relief valves • Reverse acting:

The Single Seated 119-R and 118-R are identical to the 119 and 118 valve except reverse seated.

The 119-R and 118-R gives accurate relief where the pressure on the discharge is constant such as when relieving to the atmosphere. It is tight on shut-off but the pressure setting is affected by both inlet and outlet pressure variations.

The disc is held to the seat by spring or weight loading (normally closed). The pilot line senses the increase in up-stream pressure and signals the diaphragm to open the main valve.

Steam and air capacity tables. see pages 16-17. Water capacity table, see page 15.



On self contained regulators for reduced pressures above 60 psi, a piston operator is necessary and replaces the diaphragm operator at additional cost.

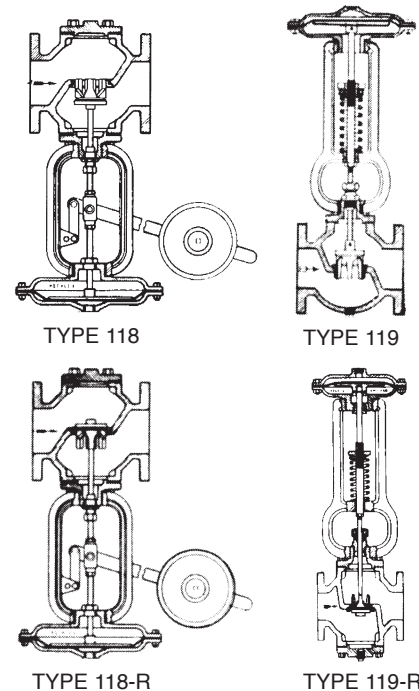

SHIPPING WEIGHT • TYPE 114 • 114-R • 116 • 116-R • 118 • 118-R • 119 • 119-R

Size	½	¾	1	1¼	1½	2	2½	3	4	5	6	8	10	12
Screwed	31	31	33	36	40	90	100	130	—	—	—	—	—	—
Standard Flanged	—	—	—	—	—	95	110	140	170	235	285	450	600	925
Extra Heavy Flanged	—	—	—	—	—	100	120	150	185	245	290	500	650	1000

TYPE 10 PRESSURE REDUCING VALVE

Bronze Body and Trim
Single Seat — Tight Closing
Spring Range 5 to 30; 15 to 100
Water, Oil, Air Service

Maximum allowable pressure on plumbing fixtures is generally about 40 pounds. When the supply is from high pressure mains, or that may, in case of fire, be under high pressures temporarily, it is necessary to use pressure reducing valves to protect the fixtures and insure satisfactory operation. In industrial plants, water regulators frequently are required for processing and other specific purposes.

While the Type 10 Regulator is widely used for water pressure reduction, it is equally well adapted for the reduction of air if the operating pressure conditions are within its limitations. **Maximum initial pressure 150 psi. Minimum reduced pressure 5 psi.**

Construction/Operation: The valve body and trim are bronze and the spring case is cast iron. It is equipped with a standard renewable composition disc and has a neoprene diaphragm.

Removal of the bottom cap exposes the disc for inspection or replacement. The disc is mounted on a plate guide that slips into the pusher yoke. The assembly may be easily removed by hand. Complete inspection or replacement of any part can be made without removal of the valve body from the pipe line.

Port area is full pipe area. Normally the valve is forced open by the compression spring. Flow enters over the disc and comes in contact with the diaphragm as it passes to the outlet. When the outlet pressure on the diaphragm overcomes the spring, the valve closes against the inlet pressure.

For water pressure reducing valve, pipe sizes larger than 1", see Type 700, page 8.



TYPE 10

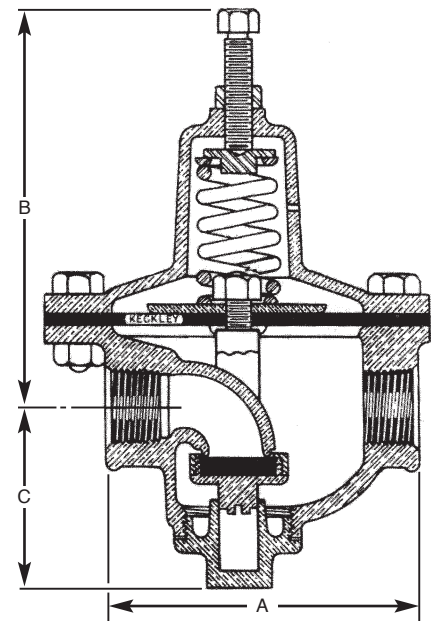

DIMENSIONS — WEIGHTS (approximate)

Bronze Body Maximum Working Pressure 150 lbs.		Bronze Body Screwed Ends			Shipping Weight
SIZE Inches	A	C	B		
½	4¼	2½	5½	9	
¾	4¼	2½	5½	9	
1	4¼	2½	5½	9	

MAXIMUM CAPACITIES • CUBIC FEET OF AIR PER MINUTE

Inlet Pressure	Outlet Pressure	VALVE SIZES			
		¼	½	¾	1
25	10	4.4	17.5	39	70
50	8-30	7.3	29	65	115
75	8-45	10.0	40	90	160
75	55	8.3	33	75	135
100	8-55	12.5	50	110	200
150	8-60	18.8	75	170	300

MAXIMUM CAPACITIES • GALLONS OF WATER PER MINUTE

Inlet Pressure	Outlet Pressure	VALVE SIZES				Inlet Pressure	Outlet Pressure	VALVE SIZES			
		¼	½	¾	1			¼	½	¾	1
25	10	.9	3.5	7.9	14	75	40	1.4	5.5	12.4	22
25	15	.7	3.0	6.7	12	75	60	.9	3.5	7.9	14
25	20	.5	2.0	4.5	8	100	10	2.2	8.7	19.7	35
50	10	1.4	5.7	12.9	23	100	30	1.9	7.5	16.9	30
50	20	1.2	5.0	11.2	20	100	50	1.6	6.5	14.6	26
50	30	1.0	4.0	9.0	16	150	20	2.7	10.7	24	43
50	40	.7	3.0	6.7	12	150	40	2.4	9.5	21	38
75	10	1.8	7.2	16.3	29	150	60	2.2	8.7	19.7	35
75	20	1.7	6.7	15.2	27	—	—	—	—	—	—

DATA REQUIRED WHEN ORDERING:

1. Size
2. Media
3. Inlet pressure
4. Outlet pressure
5. Capacity

TYPE 11A PRESSURE REDUCING VALVE

250 lbs. Cast Iron Body
Single Seat — Tight Closing
Steam, Air, Water, Oil Service

Service: The KECKLEY 11A Pressure Reducing Valve is full ported, tight closing with a composition disc, easily changed or renewed. It will maintain a constant reduced pressure on a multitude of general industrial applications where capacity and compactness are desired. It is recommended on applications with "dirty" steam.

Operation: Reduced pressure under the diaphragm balances the spring loading and positions the disc. Changes in reduced pressure opens or closes the valve tending to keep the reduced pressure constant. Adjustment for reduced pressure is accomplished by compressing the diaphragm spring. See chart for reduced pressure ranges obtained per spring and valve size.

Construction: The Type 11A, sizes $\frac{3}{8}$ " to 2" has a 250 lb. cast iron body. Available trim is bronze or stainless steel. **For steam service, the valve is supplied with phosphor bronze diaphragm and teflon valve disc. For air or liquid service, the valve is standard with a rubber diaphragm and neoprene valve disc.**

The spring case is of one piece construction with a hex shaped flange using 6 bolts providing easy removal and maximum safety.

REDUCED PRESSURE ADJUSTING SPRINGS

Valve Size	#1 Spring	#2 Spring	#3 Spring
$\frac{3}{8}$ "- $\frac{1}{2}$ "	5-25 lb.	25-50lb.	50-100 lb.
$\frac{3}{4}$ "-1"	5-20 lb.	20-45 lb.	45-75 lb.
1 $\frac{1}{4}$ "-1 $\frac{1}{2}$ "	5-15 lb.	15-40 lb.	30-60 lb.
2"	5-15 lb.	15-30 lb.	30-50 lb.

DATA REQUIRED WHEN ORDERING

Size
Trim (bronze or stainless steel)
Media
Inlet pressure
Outlet pressure
Capacity

Steam and air capacity tables, see pages 16-17. Water capacity table, see page 15 .

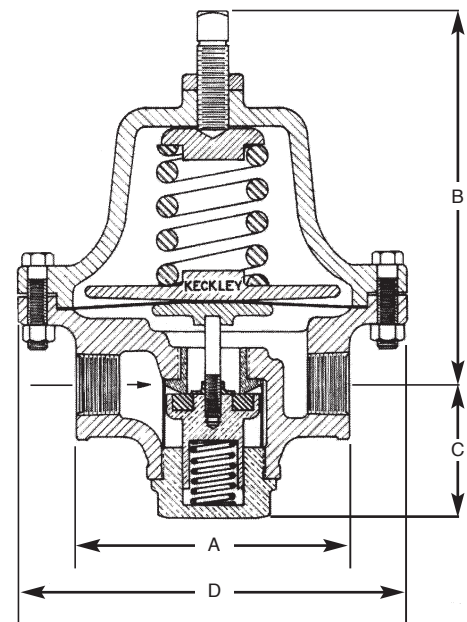
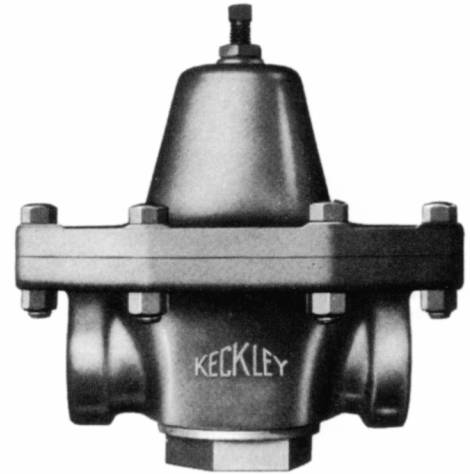

SINGLE SEAT—TIGHT CLOSING
SELF CONTAINED—TYPE 11-A

DIMENSIONS—WEIGHTS (approximate)

Size	$\frac{3}{8}$ "- $\frac{1}{2}$ "	$\frac{3}{4}$ "	1"	1 $\frac{1}{4}$ "	1 $\frac{1}{2}$ "	2"
A	4 $\frac{1}{4}$	5 $\frac{1}{2}$	5 $\frac{1}{2}$	6 $\frac{1}{2}$	6 $\frac{1}{2}$	7 $\frac{1}{4}$
D	6	8	8	9	9	9
B	6 $\frac{1}{2}$	8 $\frac{1}{2}$	8 $\frac{1}{2}$	9 $\frac{1}{2}$	9 $\frac{1}{2}$	9 $\frac{1}{2}$
C	2 $\frac{1}{2}$	2 $\frac{3}{4}$	2 $\frac{3}{4}$	2 $\frac{3}{4}$	2 $\frac{3}{4}$	3 $\frac{1}{16}$
Port Area	$\frac{3}{4}$	1	1	1 $\frac{1}{2}$	1 $\frac{1}{2}$	2
Shipping Weight	12	28	28	28	38	60

TYPE D PRESSURE REDUCING VALVE

200 lb. Bronze Body, Stainless Steel Trim
Single Seat — Tight Closing
Spring Range 5 to 30; 15 to 100
Steam, Air Service

This pressure reducing regulator is a direct-acting spring-loaded valve, designed with a large diaphragm, and effective working area to secure sensitive control and more accurate regulation of reduced pressure, and is recommended for small systems where a tight closing valve is required to prevent the pressure on the system from building up.

Construction: These regulators are made with bronze body and stainless steel valve, seat and spring.

A metal diaphragm is used for steam service. A rubber diaphragm with fabric insert is used for air service.

The advantage of this regulator is that it is compact and light in weight, simply constructed, easily adjusted, economical and accurate for small systems where a tight closing valve is required.

Operation: This regulator is normally held open by the spring tension, and the steam or air enters diaphragm chamber through the port on delivery side of valve, the pressure under the

diaphragm forcing the diaphragm upward against tension of spring, causing main valve to close, forming a balance between the delivery pressure and the tension of the adjusting spring.

The reverse or indirect action is very simple and has few moving parts. Adjustment is easily made with common tools. Turning the adjusting screw into the top cap increases the reduced pressure. Capacity of this valve is approximately one-third the pipe line of any given size. The Type D Valve is a high quality valve and can be recommended for light exacting service.

Applications: Controlling steam pressure to stills, kettles, sterilizers, presses, washers and many others for both air and steam.

DATA REQUIRED WHEN ORDERING:

- Inlet pressure
- Outlet pressure
- Media
- Capacity



TYPE D

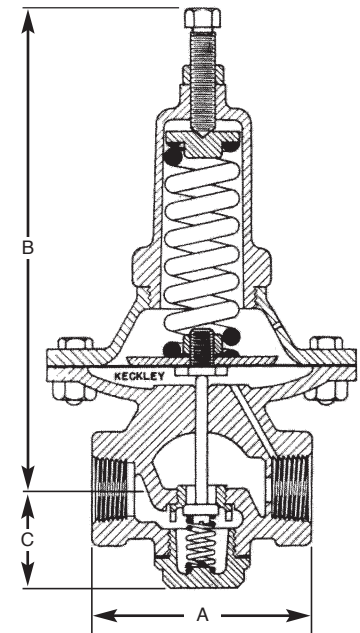

DIMENSIONS—WEIGHTS (approximate)

BRONZE BODY Screwed Ends				
SIZE	A Inches	B Inches	C Inches	Shipping Weight
¼	3%	8 ⁵ / ₁₆	1%	9
⅜	3%	8 ⁵ / ₁₆	1%	9
½	3%	8 ⁵ / ₁₆	1%	9
¾-1	3%	8 ⁵ / ₁₆	1%	9

MAXIMUM CAPACITIES

Inlet Pressure	Outlet Pressure	Pounds of Saturated Steam Per Hour				Inlet Pressure	Outlet Pressure	Cubic Feet of Air Per Minute			
		VALVE SIZE						VALVE SIZE			
		¼	⅜	½	¾-1			¼	⅜	½	¾-1
25	5 to 15	6.7	15	27	60	25	5 to 15	2.7	6.2	10.9	25
50	5 to 30	10.8	24	43	97	50	5 to 30	4.5	10.2	18.2	41
75	5 to 45	15	34	60	135	75	5 to 45	6.2	14.1	25	56
75	55	12.5	28	50	110	75	55	5.2	11.7	21	47
100	5 to 55	19.7	44	79	180	100	5 to 55	7.8	17.6	31	70
100	80	14.8	33	59	135	100	80	6.2	14.1	25	56
150	5 to 80	28	63	110	250	150	5 to 80	11.7	26	47	105
150	100	26	58	100	130	200	5 to 105	15.0	34	60	135
200	5 to 105	36	81	145	320	—	—	—	—	—	—

DRIP PAN ELBOWS

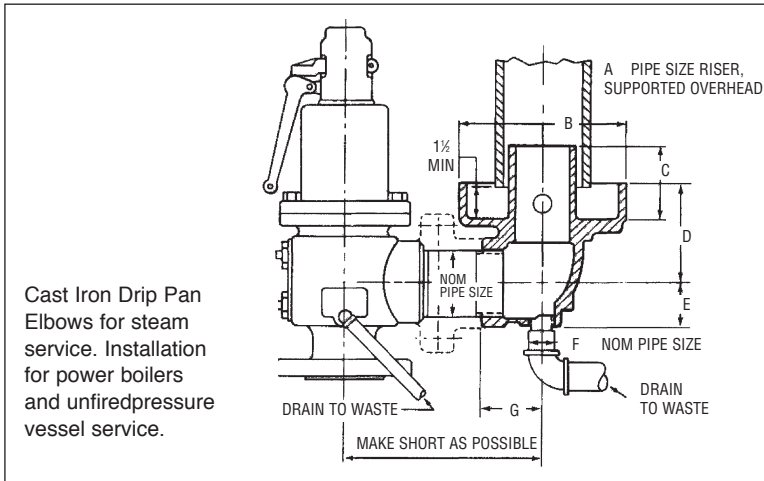

DIMENSIONS

Size	A	B	C	D	E	F	G	Wt. Lbs.
3/4-1"	1 1/2	3 3/4	1 3/4	2 3/4	1 1/2	3/4	1 1/2	2
1 1/4-1 1/2"	2 1/2	5 1/2	2 1/2	4 1/4	1 5/8	3/8	2 1/8	5
2"	3	6 1/4	2 3/4	3 3/4	1 5/8	1/2	2 1/4	7
2 1/2"	3 3/4	7 3/8	3	4 3/8	1 5/8	3/4	2 1/4	11
3"	4	8	3 1/2	4 1/4	2 3/8	3/4	3 1/8	19
4"	6	9 3/4	4 1/2	5 1/4	2 3/8	3/4	3 3/4	27
6"	8	12 3/4	6 1/2	7 3/8	4 3/8	3/4	8	80
8"	10	16 1/2	7 1/2	9 3/8	5 3/8	1	10 3/4	150
10"	FABRICATED STEEL—CONSULT FACTORY							

6" and 8" elbows have integral 125 lb. ANSI flange.

CAPACITIES OF CONTROL VALVES FOR WATER

Water Capacity Table Gallons Per Minute

PRESSURE DROP—pounds per square inch

VALVE SIZES	PRESSURE DROP—pounds per square inch												
	1	5	10	20	30	40	50	60	80	100	125	150	
1/2	2.7	6	9.1	13	16	19	21	25	27	31	34	39	
3/4	5.4	13	19	26	32	39	42	50	58	63	70	80	
1	8	18	27	38	48	58	62	73	81	90	100	120	
1 1/4	13	30	48	62	79	92	100	120	140	150	160	180	
1 1/2	22	48	73	99	120	150	160	190	220	240	270	300	
2	30	67	100	140	170	210	230	270	300	350	380	420	
2 1/2	44	95	150	200	250	300	350	390	440	500	550	620	
3	68	140	230	300	370	450	500	590	650	720	800	900	
4	180	400	600	800	1000	1300	1400	1600	1800	2000	2400	2500	
6	360	790	1200	1700	2100	2500	2700	3200	3600	4100	4800	5000	
8	740	1700	2600	3500	4400	5400	5900	6900	7700	8800	9800	12000	

PRESSURE DROP IS DIFFERENCE BETWEEN INLET PRESSURE AND REDUCED PRESSURE.

MULTIPLIERS TO BE USED

VALVE NO.	%	1/2	3/4	1	1 1/4	1 1/2	2	2 1/2	3	4	5	6	8	10
700		.40	.40	.40	.35	.35	.54	.44	.54	.35				
701							1.60	1.30	1.30	.90	1.00	1.00	.90	1.00
114-114R-116-116R		*	*	*	*	*	*	*	*	*	*	*	*	*
118-118R-119-119R		.55	.55	.55	.55	.55	.55	.55	.55	.55	.55	.55	.55	.55
11A	.60	.60	.40	.60	.40	.40	.30							

*USE TABLE AS SHOWN

CAPACITIES OF PRESSURE REGULATORS FOR STEAM

The capacity table has been prepared to simplify the selection of the proper size regulator for steam service.

It is based on the differences in pressure across the valve seat or inlet side of valve versus outlet side. Pressure reductions of a magnitude greater than those shown do not materially increase the quality of

steam that will flow through the valve and have not, therefore, been listed.

If the exact pressures desired are not shown, the capacity may be found by interpolation. This table is not intended for use in sizing pipe lines, but only for determining the proper size of regulating valve, as it is often the case that full pipe size

regulators are not required. Rated capacities do not increase for lower reduced pressures than shown for each inlet pressure.

Note corrections for superheated steam and multiplier for specific valve types at bottom of page.

SATURATED STEAM—POUNDS PER HOUR

Inlet Pressure	Outlet Pressure	Valve Size										
		½"	¾"	1"	1¼"	1½"	2"	2½"	3"	4"	6"	8"
30	2-10	130	232	432	596	1160	2030	3000	4400	7700	17800	34000
50	5-20	130	344	616	872	1600	2900	4200	6200	10800	26200	48000
	30	178	320	568	768	1500	2600	4000	5700	10000	38500	44000
60	5-25	215	392	704	960	1850	3300	4800	7000	12000	29000	60000
	40	196	352	624	880	1650	2900	4400	6300	11000	24000	52000
75	5-30	260	480	840	1160	2200	4000	5900	8500	15000	33600	70000
	50	236	424	760	1040	2000	3600	5300	7700	13000	29000	63000
100	5-50	330	600	1080	1440	2800	5000	7400	11000	18500	42000	87000
	60	320	576	1040	1400	2700	4800	7200	10500	18000	40000	85000
	80	260	464	840	1120	2200	3900	5700	8300	14000	31000	67000
125	5-60	400	736	1320	1800	3500	6200	9100	13500	23000	49400	99000
	80	380	688	1240	1680	3300	5800	8500	12500	21500	48000	97000
	100	310	560	1024	1360	2700	4800	7000	10500	17500	39700	80000
150	5-70	486	880	1584	2080	4000	7200	11000	15500	27000	60000	122000
	100	450	800	1440	1960	3800	6700	10000	14500	25000	52000	115000
	125	350	608	1120	1520	2900	5200	7700	11000	19000	43000	91000
175	5-90	560	1000	1840	2480	4800	8500	12500	18000	31000	65000	140000
	100	540	984	1760	2400	4700	8200	12000	17500	33000	64000	135000
	125	480	880	1560	2080	4200	7400	11000	15800	27000	58000	123000
	150	370	680	1200	1680	3200	5700	8400	12000	21000	44000	95000
200	5-100	600	1120	2000	2800	5200	9500	14000	21000	35000	75500	162000
	125	590	1080	1920	2640	5000	9000	13000	19000	33000	75000	150000
	150	540	984	1760	2400	4700	8200	12000	17500	30000	64000	135000
	175	410	720	1280	1760	3400	6000	9000	13000	23000	49100	110000
225	5-120	680	1200	2200	3040	5800	10500	15000	22000	38000	82000	170000
	150	660	1160	2080	2880	5500	9800	14500	21000	37000	76000	160000
	175	570	1040	1840	2480	4800	8600	13000	18500	32000	66000	140000
	200	430	760	1360	1880	3600	6400	9500	14000	24000	52000	112000
*250	5-130	770	1440	2480	3360	6700	11800	17000	25000	43000	92000	200000
	150	760	1360	2400	3280	6400	11500	16500	24500	42000	90000	190000
	175	710	1280	2240	3040	6000	10500	15700	23000	39000	83000	180000
	200	610	1100	1960	2720	5100	9200	13500	20000	34000	78000	160000
	225	450	800	1440	1960	3800	6700	10000	14500	25000	59800	110000

For Superheated steam correct figures in table as follows:

50°F. superheat multiply by .92

100°F. superheat multiply by .85

150°F. superheat multiply by .80

200°F. superheat multiply by .75

300°F. superheat multiply by .65

*Capacities for regulators at pressures higher than 250 psi as well as for larger sizes consult our engineering department.

MULTIPLIERS TO BE USED

Type of Valve	¾"	½"	¾"	1"	1¼"	1½"	2"	2½"	3"	4"	6"	8"	10"
AA-AR	*	*	*	*	*	*	*	*	*	*	*	*	*
114-114-R	*	*	*	*	*	*	*	*	*	*	*	*	*
116-116-R	*	*	*	*	*	*	*	*	*	*	*	*	*
118-118-R	.55	.55	.55	.55	.55	.55	.55	.55	.55	.55	.55	.55	.55
119-119-R	.55	.55	.55	.55	.55	.55	.55	.55	.55	.55	.55	.55	.55
11A	*	*	*	*	*	*	*	*	*	*	*	*	*

*Use Table as shown



CAPACITIES OF PRESSURE REGULATORS FOR AIR

AIR—STANDARD CUBIC FEET PER MINUTE							
Inlet Pressure	Outlet Pressure	VALVE SIZE					
		½"	¾"	1"	1¼"	1½"	2"
30	2-10	44	80	145	195	385	675
50	5-20	65	115	205	290	535	965
	30	60	105	190	255	500	865
60	5-25	70	130	235	320	616	1100
	40	65	115	210	295	550	965
75	5-30	85	160	280	385	735	1330
	50	80	140	255	345	665	1200
100	5-50	110	200	360	480	935	1670
	60	105	190	345	465	900	1600
	80	85	155	280	375	735	1300
125	5-60	135	245	440	600	1170	2070
	80	125	230	415	560	1100	1930
	100	105	185	340	455	900	1600
150	5-70	160	295	530	695	1330	2400
	100	150	265	480	655	1270	2230
	125	115	200	375	505	965	1730
175	5-90	185	335	615	825	1600	2830
	100	180	325	585	800	1570	2730
	125	160	295	520	695	1400	2470
	150	125	225	400	560	1070	1900
200	5-100	200	375	665	935	1730	3170
	125	195	360	640	880	1670	3000
	150	180	325	585	800	1570	2730
	175	135	240	426	585	1130	2000
225	5-120	225	400	735	1010	1930	3500
	150	220	385	695	960	1830	3270
	175	190	345	615	825	1600	2870
	200	145	255	455	625	1200	2130
250	5-130	255	480	825	1120	2230	3930
	150	255	455	800	1090	2130	3830
	175	235	425	745	1010	2000	3500
	200	205	365	655	905	1700	3070
	225	150	265	480	655	1270	2230
275	5-140	288	506	930	1250	2430	4290
	175	275	480	880	1190	2310	4080
	200	250	445	815	1100	2130	3760
	225	215	385	700	945	1840	3240
300	5-150	315	555	1010	1360	2650	4670
	175	305	540	990	1130	2580	4560
	200	290	515	940	1270	2460	4350
	225	265	470	860	1160	2250	3970
*325	5-170	335	595	1090	1470	2850	5030
	200	325	575	1050	1420	2750	4850
	225	305	540	990	1340	2600	4590

*Capacities for Pressure Regulators at pressures higher than 325 psi, as well as for sizes larger than 2" available on request.
Air Capacities for valves 2½" and larger, use Table on page 16 and divide by 3.

TYPES 135, 145 BACK PRESSURE VALVES

Angle or Globe Pattern
Cup Disc Type
Steam, Air, Water, Oil Service

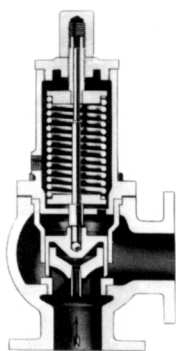

TYPE 135 ANGLE

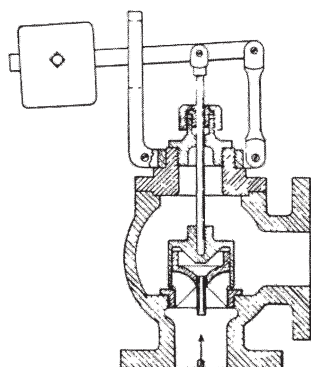

TYPE 145

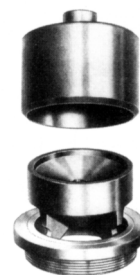

CUP DISC, SEAT-BUSHING

Cup Disc back pressure and relief valves set a new standard in valve performance giving far greater capacity with closer regulation than is possible for conventional type valves. Type 135 is recommended for any clean fluid and for pressures from 5 psi up to the maximums listed below. Type 145 is offered for 0 to 15 psi.

Design and Operation: The inner valve is cup formed and slides over a stationary piston which is part of the seat bushing casting. The edge of the cup cuts across the outlets of the passages between the piston and seat to control the flow and pressure. Valve is normally closed.

Pressure from the valve inlet is transmitted by a short tube to the space above the piston where it tends to lift the cup against the spring force. As this tube

faces upstream, the velocity head of the entering fluid is changed into additional pressure to lift the cup. The tube may extend outside the valve to transmit pressure from a remote point.

A close fitting sleeve surrounds the cup to prevent pressure in the outlet chamber from acting downward on the cup and raising the inlet pressure.

A vent in the spring housing prevents an accumulation of pressure above the disc.

Since there is always some fluid leakage between the sleeve and the cup, this vent connection should be piped back to the reservoir when liquids are used. The piping should be kept as short as possible to avoid pressure buildup above the cup.

When used as a relief valve without the sleeve and vent, the capacities are reduced

as indicated in the table. The smoother and more chatter free characteristics of the cup construction are retained.

Although the spring can be designed for a wide range of adjustment, much better regulation results if the spring is specified and designed for a definite pressure with a moderate adjustment range. The cap locks the adjusting screw and prevents leakage.

Capacity: The outstanding advantage of this valve is its very large capacity with excellent regulation at all rates of flow. The size ordinarily is half the size required with other types.

Materials: Sizes 1½ inch and smaller have bronze body and trim. Larger sizes have cast iron body and bronze trim. Prices for valves made of other materials will be supplied on request.

TYPES 135 AND 145—DIMENSIONS—WEIGHTS (approximate)

Size Inches	Globe—F to F—Inches		Angle—Cen. to F—Inches			Maximum Inlet Pressure lbs./sq. in.	Shipping Weight		Cap. Factor		
	Screwed	Flanged 125# 250#	Screwed	Flanged 125# 250#	Screwed		Flanged 125# 250#	with sleeve 5% rise	without sleeve 10% rise		
¾	4¼	—	1⅞	—	—	300	12	—	.16	.11	
1	5	—	2⅞	—	—	300	15	—	.27	.19	
1¼	5½	—	2⅞	—	—	250	16	—	.48	.33	
1½	5½	—	2½	—	—	200	17	—	.64	.45	
2	7⅞	8¼	3⅞	4¼	4¾	180	43	52	60	1.1	.77
2½	8½	9½	3⅞	4¼	5⅞	150	53	65	72	1.5	1.1
3	9½	10½	4½	5¼	5½	140	73	85	100	2.4	1.7
4	—	12¼	—	6½	6⅞	125	—	120	140	4.4	3.1
5	—	14½	—	7¼	7⅞	100	—	170	195	6.4	4.5
6	—	16¼	—	8½	8⅞	90	—	200	235	8.8	6.1
8	—	19½	—	9½	9½	80	—	350	380	16.0	11.0

TYPES 135, 145 BACK PRESSURE VALVES

Capacity Table

The maximum capacity of any back pressure valve depends on its size and on the inlet and outlet pressures at the maximum rate of flow. The capacity depends also on the type and design of control mechanism. It is necessary to have all this information to figure the capacity accurately. Although a very large capacity can be obtained from any back pressure or relief valve if the inlet pressure rises enough, only the capacity obtainable with a moderate and safe pressure rise is important.

The capacities of valves in this bulletin are based on 10% rise or accumulation in inlet pressure above the set opening pressure, except Type 135 based on 5% rise.

Don't base your selection of valve size merely on size of pipe.

1. To find Valve Capacity—Multiply Capacity Factor by Orifice Capacity.
2. To find Valve Size needed—Divide Required Capacity by Orifice Capacity to obtain Capacity Factor. Then use Table No. 1.

Capacity Factors in Table No. 1 represent the capacity of each valve, with good regulation, as compared to the capacity of a standard orifice under the same conditions.

Orifice Capacities in Tables Nos. 2, 3, 4 and 5 are the rates of flow through a perfect (100% coefficient) orifice or nozzle of 1 sq. in. area for various combinations of inlet and outlet pressures.

Corrections for superheat and for fluids of different specific gravities are shown.

Maximum inlet temperature 450°F.

Example: Find steam capacity of 3" Type 135 Inlet pressure 20 lbs. —Outlet 8 lbs. or lower. Capacity Factor = 2.4 (See Table No. 1). Orifice Capacity = 1,900 lbs. per hr. (Table No. 3). Valve Capacity = 2.4 x 1,900 = 4,560 lbs. per hr. steam.

table no. 1—capacity factors—valves

	3/8"	1/2"	3/4"	1"	1 1/4"	1 1/2"	2"	2 1/2"	3"	4"	5"	6"	8"	10"	12"	14"
No. 135			.16	.27	.48	.64	1.1	1.5	2.4	4.4	6.4	8.8	16			

table no. 2—orifice capacities—high pressure steam

Outlet Pressure Lbs. per Square Inch Gage	Initial Gage Pressure—Lbs. per Square Inch							
	200	175	150	125	100	80	60	50
	Lbs. of Steam per Hour per Square Inch of Orifice							
125	10570	8820	6270					
100	10900	9580	7960	5640				
80	10900	9650	8400	6840	4620			
60	10900	9650	8400	7150	5720	4100		
50	10900	9650	8400	7150	5900	4670	2760	
40	10900	9650	8400	7150	5900	4900	3580	2550
30	10900	9650	8400	7150	5900	4900	3885	3225
25	10900	9650	8400	7150	5900	4900	3900	3360
20-0	10900	9650	8400	7150	5900	4900	3900	3400

If the steam is initially superheated multiply the above weights by
1—(0.00065 x degrees Fahr. superheat)

table no. 3—orifice capacities—low pressure steam

Outlet Pressure Lbs. per Square Inch Gage	Initial Gage Pressure—Lbs. per Square Inch							
	40	30	25	20	15	10	8	5
	Lbs. of Steam per Hour per Square Inch of Orifice							
30	2310							
25	2710	1575						
20	2840	2050	1480					
15	2900	2370	1930	1385				
10	2900	2400	2115	1780	1235			
8	2900	2400	2150	1900	1540	760		
5	2900	2400	2150	1900	1600	1110	860	
1	2900	2400	2150	1900	1600	1310	1075	915
O-Vac.	2900	2400	2150	1900	1600	1330	1210	985

If the steam is initially superheated multiply the above weights by
1—(0.00065 x degrees Fahr. superheat)

table no. 4—orifice capacities for air

Outlet Pressure Lbs. per Square Inch Gage	Initial Gage Pressure—Lbs. per Square Inch									
	100	90	80	70	60	50	40	30	20	10
	Cu. Ft. per Min. of Free Air (60°F.—14.7#/sq. in.) per Sq. In.									
70	1886	1535	1100							
60	2035	1770	1453	1023						
50	2090	1880	1643	1355	958					
40	2100	1913	1725	1505	1235	881				
35	2100	1913	1735	1530	1317	1025	590			
30	2100	1913	1735	1550	1350	1120	802			
25	2100	1913	1735	1550	1370	1165	910	533		
20	2100	1913	1735	1550	1370	1185	978	696		
15	2100	1913	1735	1550	1370	1185	1002	812	460	
10	2100	1913	1735	1550	1370	1185	1002	815	580	
5	2100	1913	1735	1550	1370	1185	1002	818	635	375
0	2100	1913	1735	1550	1370	1185	1002	818	635	446

For other gases, divide above CFM by $\sqrt{\text{specific gravity of the gas.}}$

table no. 5—orifice capacities for water

Pressure Drop	Pressure Drop through Orifice—Lbs. per Square Inch											
	100	85	70	60	50	40	30	25	20	15	10	5
GPM per Square Inch	380	350	318	294	269	240	208	190	170	147	120	85

For other liquids, Ft. above GPM by $\sqrt{\text{specific gravity of the liquid.}}$

TYPE 40 — A.S.M.E. STANDARD — STEAM OR AIR
TYPE 41 — A.S.M.E. STANDARD — STEAM OR AIR
TYPES 42, 43, 44 — LIQUIDS • SAFETY AND RELIEF VALVES

Bronze Body
Bronze or Stainless Steel Trim

Type 40 (side outlet) and Type 41 (top outlet) Bronze Pop Safety Valves

Pressure Settings:

Steam to 250 psi 406°F.
 Air/Gas to 300 psi 300°F.

Consult factory regarding stainless steel trim for higher pressure settings. These valves meet A.S.M.E. requirements and are NB Certified. Regulators and pressure adjustment screws are both sealed after final tests before shipment.

Recommended for installation on, or protection of steam boilers, generators, unfired pressure vessels, line pressure reducing valves, etc. Sizes ½" through 2½". For larger sizes, consult factory.

Types 42, 43, 44 (Liquids) Bronze Relief Valves

Relief Valves: These RELIEF VALVES are furnished for any service where the pressure media does not attack bronze and the temperature is not higher than 406°F. and maximum pressure not higher than 300 psi designed for protection against overpressure in pumps, pipe lines, tanks, etc.

Constructed of bronze with stainless steel spindle. Springs adjustable ±5 psi above or below the set pressure.

Type 42 is standard for use where set pressure is fairly constant. Special locking caps are available at additional cost.

Type 43 is standard with handwheel for ease in changing the set pressure.

Type 44 has lifting lever required for some applications where inspection tests are advisable to show valve is operative.

DATA REQUIRED WHEN ORDERING:

- Size
- Orifice
- Set pressure
- Media
- Capacity
- 3% or 10% accumulation

Lbs./Hour Steam, 90% basis, 3% Accumulation: The capacities shown on page 21 are for saturated steam and apply to valves for use on power boilers in accordance with current A.S.M.E. Code, Section 1.

Lbs./Hour Steam, 90% basis, 10% Accumulation: The capacities shown on page 21 are for saturated steam and are in accordance with A.S.M.E. Unfired Pressure Vessel Code, Section VIII.

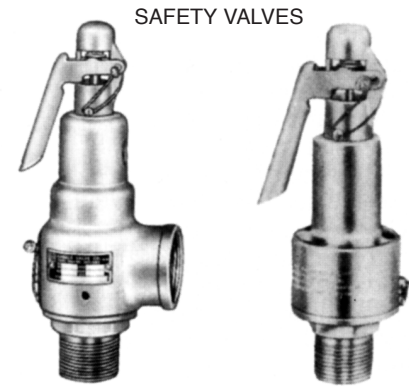

TYPE 40 TYPE 41

SCFM Air, 10% Accumulation: The capacities shown on page 21 are for air service.

RELIEF VALVES



TYPE 42 TYPE 43 TYPE 44

In all the designs, the outlet opening is in the base casting. This makes it unnecessary to break the connection

to take valve apart for cleaning. Size ½" through 3".

CAPACITIES IN GALLONS OF WATER PER MINUTE AT 25% OVERPRESSURE

TYPES 42, 43, 44 RELIEF VALVES

Set Pressure Psig	Capacity (GPM)								
	½"	¾"	1"	1¼"	1½"	2"	2½"	3"	3½"
25	8	11	16	37	56	95	152	218	
50	11	14.5	22.5	51	75	109	217	315	
75	13	16	27	60	83	120	265	385	
100	16	20	32.5	68	90	131	306	446	
125	18	22.5	36	76	98	142	341	500	
150	20	25	39	81	105	151.5	376	547	
175	21.5	27	42	87	111.5	158	405	589	
200	23	31	45	92	117	165	430	630	
225	24	34	48	96	124	171.5	459	668	
250	25	36.5	50.5	100	130	177	484	706	
275	25.5	39	53	104	135.5	183	506	747	
300	26	42	55	107.5	142	189	530	785	

DIMENSIONS—WEIGHTS (approximate)

Size	A		B	C	Weight
	Type 42-43	Type 44			
½"	5	5½"	1½"	1½"	1
¾"	6⅞"	7"	1⅞"	2¼"	2
1"	7"	8"	2⅞"	2⅞"	4
1¼"	8"	9"	2⅞"	3"	6
1½"	9½"	10⅞"	2½"	3½"	8
2"	9⅞"	10"	2⅞"	3⅞"	11
2½"	10"	13⅞"	3"	3"	16
3"	12"	14"	3½"	4"	25

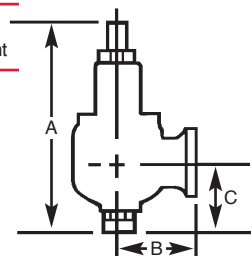



STEAM/AIR CAPACITIES—TYPES 40 AND 41

To correct capacities for superheat or temperature other than 60°F, consult factory.

Orifice Area	D			E			F			G			H			J		
	.121 Sq. In.			.216 Sq. In.			.338 Sq. In.			.554 Sq. In.			.863 Sq. In.			1.414 Sq. In.		
	Set Press. PSIG	Lbs./Hr. Steam 3% Acc.	Lbs./Hr. Steam 10% Acc.	SCFM Air 10% Acc.	Lbs./Hr. Steam 3% Acc.	Lbs./Hr. Steam 10% Acc.	SCFM Air 10% Acc.	Lbs./Hr. Steam 3% Acc.	Lbs./Hr. Steam 10% Acc.	SCFM Air 10% Acc.	Lbs./Hr. Steam 3% Acc.	Lbs./Hr. Steam 10% Acc.	SCFM Air 10% Acc.	Lbs./Hr. Steam 3% Acc.	Lbs./Hr. Steam 10% Acc.	SCFM Air 10% Acc.	Lbs./Hr. Steam 3% Acc.	Lbs./Hr. Steam 10% Acc.
10	133	152	54	237	271	96	371	423	151	607	694	247	946	1081	385	1550	1771	630
15	157	179	64	281	319	114	440	500	178	721	819	292	1123	1276	454	1840	2091	744
20	182	206	73	325	368	131	509	576	205	835	944	336	1300	1471	524	2131	2410	858
25	207	234	83	370	417	148	579	653	232	948	1070	381	1478	1666	593	2421	2730	972
30	232	261	93	414	466	166	648	729	259	1062	1195	425	1655	1861	663	2711	3050	1086
35	257	291	104	458	520	185	717	813	289	1176	1333	474	1832	2076	739	3001	3401	1211
40	282	321	114	503	573	204	787	897	319	1290	1470	523	2009	2291	815	3292	3753	1336
45	307	351	125	547	627	223	856	981	349	1403	1608	572	2186	2505	892	3582	4105	1461
50	331	381	136	592	681	242	926	1065	379	1517	1746	621	2363	2720	968	3872	4456	1586
55	356	411	146	636	734	261	995	1149	409	1631	1884	671	2540	2934	1045	4163	4808	1711
60	381	442	157	680	788	281	1064	1233	439	1745	2022	720	2718	3149	1121	4453	5160	1837
65	406	472	168	725	842	300	1134	1317	469	1858	2159	769	2895	3364	1197	4743	5511	1962
70	431	502	179	770	896	319	1205	1401	499	1974	2297	818	3076	3578	1274	5039	5863	2087
75	457	532	189	815	949	338	1276	1486	529	2091	2435	867	3258	3793	1350	5338	6215	2212
80	482	562	200	861	1003	357	1347	1570	559	2209	2573	916	3440	4008	1426	5637	6566	2337
85	508	592	211	907	1057	376	1419	1654	589	2326	2710	965	3623	4222	1503	5936	6918	2462
90	534	622	221	952	1110	395	1490	1738	619	2443	2848	1014	3805	4437	1579	6235	7270	2588
95	559	652	232	998	1164	414	1562	1822	648	2560	2986	1063	3988	4651	1656	6534	7621	2713
100	585	682	243	1044	1218	434	1633	1906	678	2677	3124	1112	4170	4866	1732	6833	7973	2838
105	610	712	254	1089	1272	453	1705	1990	708	2794	3262	1161	4353	5081	1808	7132	8325	2963
110	636	742	264	1135	1325	472	1776	2074	738	2911	3399	1210	4535	5295	1885	7431	8676	3088
115	661	773	275	1181	1379	491	1848	2158	768	3029	3537	1259	4718	5510	1961	7730	9028	3213
120	687	803	286	1226	1433	510	1919	2242	798	3146	3675	1308	4900	5725	2038	8029	9380	3339
125	713	833	296	1272	1487	529	1991	2326	828	3263	3813	1357	5083	5939	2114	8328	9731	3464
130	738	863	307	1318	1540	548	2062	2410	858	3380	3950	1406	5265	6154	2190	8627	10080	3589
135	764	893	318	1364	1594	567	2134	2494	888	3497	4088	1455	5448	6368	2267	8926	10430	3714
140	789	923	329	1409	1648	586	2205	2578	918	3614	4226	1504	5630	6583	2343	9225	10780	3839
145	815	953	339	1455	1701	606	2277	2662	948	3731	4364	1553	5813	6798	2420	9524	11130	3964
150	841	983	350	1501	1755	625	2348	2746	978	3849	4502	1602	5995	7012	2496	9823	11480	4090
160	892	1043	371	1592	1863	663	2491	2915	1037	4083	4777	1700	6360	7442	2649	10420	12190	4340
170	943	1104	393	1683	1970	701	2634	3083	1097	4317	5053	1798	6725	7871	2802	11010	12890	4590
180	994	1164	414	1775	2077	739	2777	3251	1157	4551	5328	1897	7090	8300	2954	11610	13590	4841
190	1045	1224	436	1866	2185	778	2920	3419	1217	4786	5604	1995	7455	8729	3107	12210	14300	5091
200	1096	1284	457	1957	2292	816	3063	3587	1277	5020	5879	2093	7820	9159	3260	12810	15000	5341
210	1148	1344	478	2049	2400	854	3206	3755	1337	5254	6155	2191	8185	9588	3413	13410	15700	5592
220	1199	1404	500	2140	2507	892	3349	3923	1396	5489	6430	2289	8550	10010	3565	14000	16410	5842
230	1250	1465	521	2231	2615	931	3492	4091	1456	5723	6706	2387	8915	10440	3718	14600	17110	6092
240	1301	1525	543	2323	2722	969	3634	4259	1516	5957	6981	2485	9280	10870	3871	15200	17810	6343
250	1352	1585	564	2414	2829	1007	3777	4428	1576	6191	7257	2583	9645	11300	4024	15800	18520	6593
260	1403	1645	586	2505	2937	1045	3920	4596	1636	6426	7533	2681	10000	11730	4177	16400	19220	6843
270	1455	1705	607	2597	3044	1084	4063	4764	1696	6660	7808	2779	10370	12160	4329	16990	19920	7094
280	1506	1766	628	2688	3152	1122	4206	4932	1755	6894	8084	2877	10730	12590	4482	17590	20630	7344
290	1557	1826	650	2779	3259	1160	4349	5100	1815	7128	8359	2975	11100	13020	4635	18190	21330	7594
300	1608	1886	671	2871	3367	1198	4492	5268	1875	7363	8635	3073	11460	13450	4788	18790	22030	7845
Approx. 1 PSIG Increments																		
5	6	2	9	11	4	14	17	6	24	28	10	37	43	15	60	70	25	
Approx. 5 PSIG Increments																		
25	30	11	46	54	19	72	84	30	118	138	49	183	215	77	299	350	125	
Approx. 10 PSIG Increments																		
51	60	21	92	107	38	143	168	60	235	275	98	365	430	153	598	700	250	

Valves set under 15 PSIG are not stamped with A.S.M.E. Code Symbol stamp.

DIMENSIONS • WEIGHTS (approximate) • TYPES 40 AND 41

Type	Inlet Male NPT	Orifice	Outlet Female NPT	A	B	C	Weight	Type	Inlet Male NPT	Orifice	Outlet Female NPT	A	B	C	Weight
40	½	D	¾	6½	1%	2%	1½	40	1¼	G	1½	9%	2%	3%	5½
40	¾	D	¾	6½	1%	2%	1½	40	1½	G	1½	10	2%	3%	5½
41	½	D	—	6½	—	—	1¼	41	1¼	G	—	9%	—	—	5
40	¾	E	1	7½	1%	2%	2½	40	1½	H	2	10%	2%	3%	7¼
40	1	E	1	7½	1%	2½	2½	40	2	H	2	11%	2%	4%	8
41	¾	E	—	7½	—	—	2¼	41	1½	H	—	10%	—	—	7¼
40	1	F	1¼	8½	2	2%	3½	40	2	J	2½	13%	3%	4%	15½
40	1¼	F	1¼	8½	2	2%	3½	40	2½	J	2½	14	3%	4½	15½
41	1	F	—	8½	—	—	3¼	41	2	J	—	13%	—	—	15

Model 40-S available only ½" x ¾", ¾" x 1", 1" x 1¼", 1¼ x 1½", 1½" x 2", and 2" x 2½".

TYPE 301 — CAST IRON BODY, STAINLESS STEEL TRIM (SEMI-NOZZLE)
 TYPE 401 — CAST STEEL BODY, STAINLESS STEEL TRIM (FULL NOZZLE)
 TYPE 402 — CAST STEEL BODY, STAINLESS STEEL TRIM (FULL NOZZLE)
 SAFETY VALVES

Steam, Air,
 Non-Hazardous Gas Service

Pressure & Temperature Limits:

Type 301	250 psig–406°F.
Type 401	505 psig–750°F.
Type 402	1000 psig ¹ –750°F.

Applications:

- Steam boilers and generators
- Pressure reducing stations
- Air/gas compressors—reciprocating or rotary
- Pressure vessels—including tanks, receivers, intercoolers, oil-gas separators, lines.

Features: Type 301:

Heavy duty construction of high quality cast iron with stainless steel semi-nozzle trim. Bolted bonnet design for easy maintenance. Seats lapped to optical flatness. Dual control rings offer easy adjustability for precision opening with minimum preopen or simmer and exact blow-down control. Heavy duty lift lever assembly. Every valve 100% tested/inspected for pressure setting, blow-down and leakage. All adjustments are factory sealed to prevent tampering or dis-assembly.

Type 301—Cast iron. Enclosed spring. Stainless steel trim. ANSI 250# inlet flange and ANSI 125# outlet flange.

Features: Type 401–402:

Heavy duty construction of high quality cast steel with stainless steel full-nozzle trim. Steel yoke incorporates a cover-shield for guiding surfaces and provides for fully exposed spring. Other features are the same as the Type 301.

¹Note: Maximum set pressure for Type 402—

F thru M orifice	1000 psig
N and P orifice	750 psig
Q orifice	600 psig

Type 401—Cast steel. Exposed spring. Full nozzle with stainless steel trim. ANSI 300# inlet flange and 150# outlet flange.

Type 402—Same as Type 401 except ANSI 600# inlet flange and 150# outlet flange.

Available:
Drip Pan Elbows, page 15

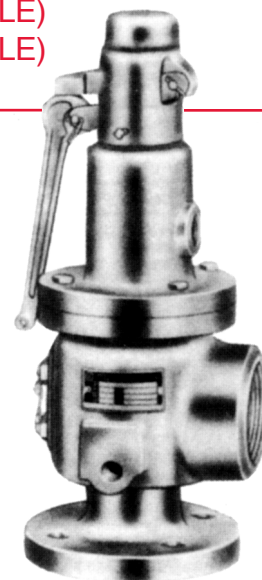

TYPE 301

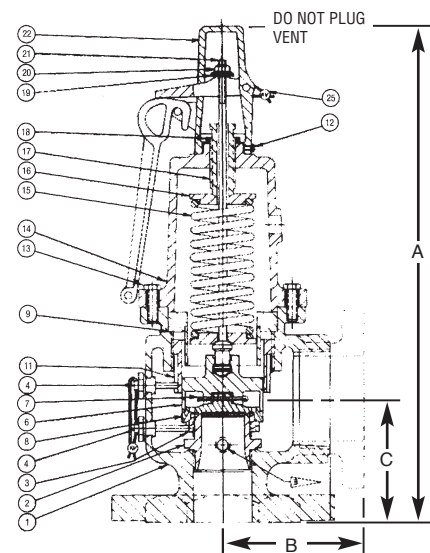

TYPE 301

PARTS AND MATERIALS — TYPE 301

No.	Part Name	Material	No.	Part Name	Material
1	Body	Iron	15	Spring	Steel Plated
2	Semi-Nozzle	Stainless Steel	16	Step-Spring	Steel Plated
3	Warn Ring	Bronze	17	Screw—Compression	Brass
4	Warn Ring Pin/Guide Pin	Brass	18	Lock Nut (Comp. Screw)	Steel Plated
6	Disc Holder	Bronze	19	Lifting Disc	Steel
7	Cotter Pin (Disc)	Stainless Steel	20	Nut (Lifting Disc)	Steel
8	Disc	Stainless Steel	21	Stem	Steel Plated
9	Lift Stop ¹	Steel	22	Cap Assembly	Iron
11	Guide	Bronze	22A	Lever	Iron
12	Screw (Cap)	Steel Plated	22B	Yoke (Lift)	Iron
13	Bolt (Body)	Steel Plated	22C	Pins (Lever/Lift Yoke)	Steel
14	Bonnet	Iron	25	Seal	Lead & Wire

¹Lift Stop furnished in Low Pressure Valves only.



STEAM/AIR CAPACITIES—TYPES 301

To correct capacities for superheat or temperature other than 60°F, consult factory ASME Standard-N.B. Certified

Orifice	J			K			L			M			N			P			Q			R		
Area	1.287 Sq. In.			1.838 Sq. In.			2.853 Sq. In.			3.60 Sq. In.			4.34 Sq. In.			6.38 Sq. In.			11.05 Sq. In.			16.0 Sq. In.		
Set Press. PSIG	Lbs./Hr. Steam 3% Acc.	Lbs./Hr. Steam 10% Acc.	SCFM Air 10% Acc.	Lbs./Hr. Steam 3% Acc.	Lbs./Hr. Steam 10% Acc.	SCFM Air 10% Acc.	Lbs./Hr. Steam 3% Acc.	Lbs./Hr. Steam 10% Acc.	SCFM Air 10% Acc.	Lbs./Hr. Steam 3% Acc.	Lbs./Hr. Steam 10% Acc.	SCFM Air 10% Acc.	Lbs./Hr. Steam 3% Acc.	Lbs./Hr. Steam 10% Acc.	SCFM Air 10% Acc.	Lbs./Hr. Steam 3% Acc.	Lbs./Hr. Steam 10% Acc.	SCFM Air 10% Acc.	Lbs./Hr. Steam 3% Acc.	Lbs./Hr. Steam 10% Acc.	SCFM Air 10% Acc.	Lbs./Hr. Steam 3% Acc.	Lbs./Hr. Steam 10% Acc.	SCFM Air 10% Acc.
	10	1453	1691	602	2077	2390	851	3220	3708	1320	4063	4697	1672	4898	5634	2005	7201	8289	2951	12466	14408	5128	17951	20886
15	1752	1996	710	2505	2821	1004	3883	4378	1558	4900	5545	1974	5908	6651	2367	8684	9786	3483	15034	17008	6054	21648	24656	8776
20	2051	2301	819	2932	3253	1158	4547	5047	1796	5737	6393	2276	6917	7668	2729	10168	11282	4016	17602	19609	6960	25346	28426	10118
25	2350	2607	928	3360	3684	1311	5210	5716	2035	6574	7241	2577	7926	8685	3091	11651	12778	454B	20171	22209	7905	29044	32196	11460
30	2650	2912	1036	3788	4116	1465	5874	6386	2273	7411	8089	2879	8935	9702	3453	13135	14274	5081	22739	24810	8831	32742	35966	12802
35	2949	3247	1156	4216	4590	1634	6537	7122	2535	8248	9022	3211	9944	10821	3852	14618	15920	5667	25307	27671	9849	36440	40113	14278
40	3248	3583	1275	4644	5065	1803	7200	7858	2797	9085	9955	3543	10953	11940	4250	16101	17566	6253	27875	30532	10867	40138	44400	15754
45	3547	3919	1395	5071	5539	1972	7864	8594	3059	9922	10887	3875	11962	13058	4648	17585	19212	6838	30443	33392	11886	43835	48407	17230
50	3847	4255	1514	5499	6014	2141	8527	9331	3321	10760	11820	4207	12971	14177	5046	19068	20858	7424	33011	36253	12904	47533	52554	18706
60	4445	4926	1753	6355	6963	2478	9854	10803	3845	12434	13685	4871	14989	16414	5843	22035	24150	8596	38147	41974	14940	54929	60848	21658
70	5043	5598	1992	7211	7912	2816	11180	12276	4369	14108	15551	5535	17008	18652	6639	25002	27442	9768	43283	47696	16977	62324	69142	24611
75	5343	5933	2112	7638	8387	2985	11844	13012	4632	14945	16484	5867	18017	19771	7037	26485	29088	10353	45851	50556	17995	66022	73289	26087
80	5642	6269	2231	8066	8861	3154	12507	13748	4894	15782	17416	6199	19026	20889	7435	27969	30733	10939	48419	53417	19013	69720	77436	27563
90	6240	6941	2470	8922	9810	3492	13834	15221	5418	17456	19282	6863	21044	23127	8232	30936	34025	12111	53555	59139	21050	77116	85730	30515
100	6839	7612	2709	9777	10759	3830	15160	16694	5942	19136	21147	7527	23062	25364	9028	33902	37317	13283	58691	64860	23086	84511	94025	33467
110	7437	8284	2948	10633	11708	4168	16487	18166	6466	20804	23012	8191	25080	27602	9825	36869	40609	14454	63828	70581	25123	91907	102319	36419
120	8036	8955	3187	11489	12658	4505	17814	19639	6990	22478	24878	8855	27098	29839	10621	39836	43901	15626	68964	76303	27159	99303	110613	39372
125	8335	9291	3307	11917	13132	4674	18477	20375	7252	23315	25811	9187	28108	30958	11019	41319	45547	16212	71532	79164	28178	103001	114760	40848
130	8634	9626	3426	12344	13607	4843	19140	21111	7514	24152	26743	9519	29117	32076	11417	42803	47192	16798	74100	82024	29196	106698	118907	42324
140	9233	10298	3665	13200	14556	5181	20467	22585	8039	25826	28609	10183	31135	34314	12214	45770	50484	17969	79236	87746	31232	114094	127201	45276
150	9831	10969	3904	14056	15505	5519	21794	24056	8563	27500	30474	10847	33153	36551	13010	48736	53776	19141	84372	93467	33269	121490	135495	48228
160	10430	11641	4143	14911	16454	5857	23121	25529	9087	29174	32340	11511	35171	38789	13806	51703	57068	20313	89508	99189	35305	128885	143789	51180
170	11028	12312	4382	15767	17403	6194	24447	27002	9611	30848	34205	12175	37189	41026	14603	54670	60360	21485	94644	104910	37342	136281	152083	54133
175	11328	12648	4502	16195	17878	6363	25111	27738	9873	31685	35138	12507	38198	42145	15001	56153	62006	22070	97212	107771	38360	139979	156230	55609
180	11627	12984	4621	16623	18352	6532	25774	28474	10135	32522	36070	12839	39208	43263	15399	57637	63651	22656	99780	110631	39378	143677	160377	57085
190	12225	13655	4860	17478	19301	6870	27101	29947	10659	34196	37936	13503	41226	45501	16196	60604	66943	23828	104917	116353	41415	151072	168671	60037
200	12824	14327	5099	18334	20250	7208	28427	31419	11183	35870	39801	14167	43244	47738	16992	63570	70235	25000	110053	122074	43451	158468	176965	62989
210	13422	14998	5338	19189	21199	7546	29754	32892	11708	37545	41667	14831	45262	49976	17788	66537	73527	26171	115189	127796	45488	165864	185259	65941
220	14021	15670	5578	20045	22149	7884	31081	34364	12232	39219	43532	15495	47280	52213	18585	69504	76819	27343	120325	133517	47524	173259	193553	69894
225	14320	16005	5697	20473	22623	8052	31744	35101	12494	40056	44465	15827	48289	53332	18983	70988	78465	27929	122893	136378	48543	176957	197700	70370
230	14619	16341	5817	20901	23098	8221	32407	35837	12756	40893	45398	16159	49298	54450	19381	72471	80110	28515	125461	139238	49561	180655	201847	71846
240	15218	17013	6056	21756	24047	8559	33734	37310	13280	42567	47263	16823	51317	56688	20178	75438	83402	29686	130597	144960	51597	188050	210141	74798
250	15816	17684	6295	22612	24996	8897	35061	38782	13804	44241	49128	17487	53335	58925	20974	78405	86694	30858	135733	150681	53634	195446	218435	77750

DIMENSIONS—WEIGHTS (approximate) • TYPE 301

Inlet ¹	Orifice	Outlet ²	A	B	C	Shipping Weight
1½" F.P.T.	J	2½" F.P.T.	18¼	3½	4¼	28
1½" FLG.	J	2½" F.P.T.	18¼	3½	4¼	30
2" FLG.	J	2½" F.P.T.	18¼	3½	4¼	33
2½" FLG.	J	2½" F.P.T.	18¼	3½	4¼	36
2" F.P.T.	K	3" F.P.T.	19¼	4	4¼	46
2" FLG.	K	3" F.P.T.	19¼	4	4¼	51
2½" FLG.	K	3" F.P.T.	19¼	4	4¼	54
3" FLG.	K	3" F.P.T.	19¼	4	4¼	58
2½" F.P.T.	L	4" F.P.T.	22	4¼	5¼	70
2½" FLG.	L	4" F.P.T.	22	4¼	5¼	76
3" FLG.	L	4" F.P.T.	22	4¼	5¼	79
4" FLG.	L	4" F.P.T.	22	4¼	5¼	81
3" F.P.T.	M	4" F.P.T.	22¼	5¼	5¼	90
3" FLG.	M	4" F.P.T.	22¼	5¼	5¼	96
4" FLG.	M	4" F.P.T.	22¼	5¼	5¼	100
4" FLG.	N	6" FLG.	23	7¼	6¼	150
4" FLG.	P	6" FLG.	26¼	7¼	6¼	176
6" FLG.	Q	8" FLG.	36¼	9¼	9¼	325
6" FLG.	R	8" FLG.	42¼	10	10¼	375

¹Inlet Flanges are ANSI B16.1-250#.

²Outlet Flanges are ANSI B16.1-125#.

For Cast Steel dimensional data, consult factory.

